

**FNG  
SERIES**

FNG.V23.1



**TRIMECCANICA**

PROGETTAZIONE - COSTRUZIONE - ASSISTENZA

# FNG

**HYDRAULIC THUMB FINGER**

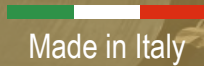

Made in Italy



## FOR MINI AND MIDI-EXCAVATORS

Trimeccanica's hydraulic thumb "FNG" is the optimal choice for complete material handling, makes it easier to pick, hold and move awkward material such as rocks, concrete, branches, and debris that does not fit into the bucket. The range of models allows the perfect match for every excavator from 0,8 to 10 ton, providing the best performance for each specific class and application.



With any  
bucket



Reinforced  
pivot areas  
provide  
extra  
strength



Extension  
for use  
with and  
without  
coupler

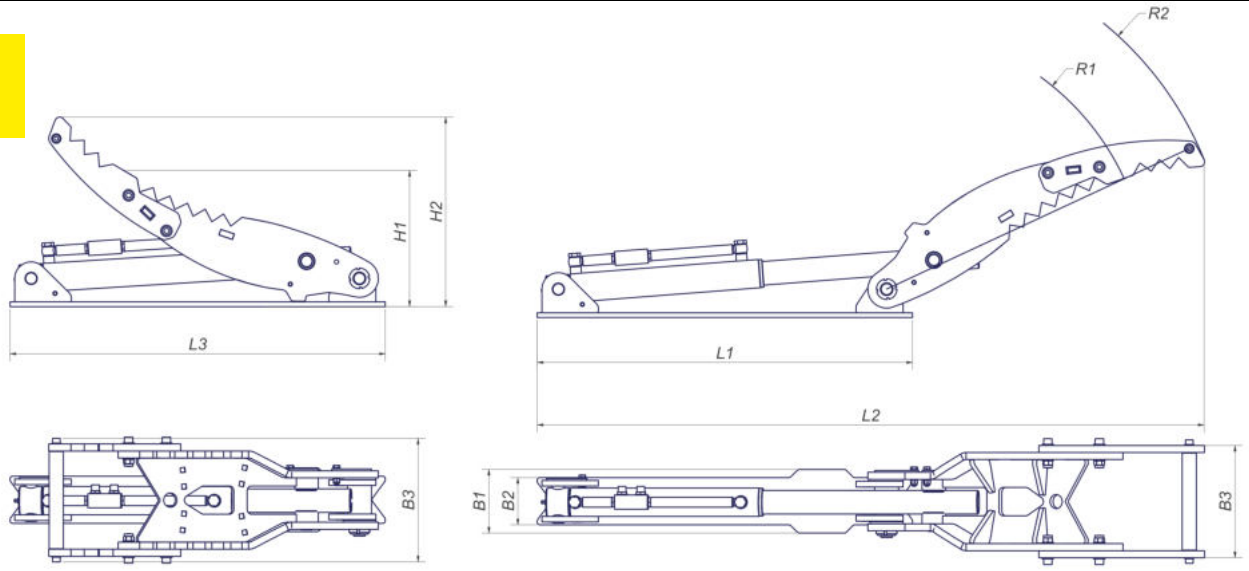

**Technical features**

Classe	Operating weight (Q)	L1	L2	L3	B1	B2	B3	H1	H2	R1	R2
T20	8 - 28	800	1420	800	135	100	270	290	400	600	730
T30	30 - 40	900	1580	900	155	122	270	345	390	700	850
T38	40 - 60	900	1700	985	155	122	270	395	436	850	1040
T46	60 - 100	1060	2135	1335	170	190	360	476	535	1150	1320

**Dimensions (mm)**

Class	Flow rate Q (l/min)	Max pressure (bar)	Push strength (ton)	Head strength (Kg)	Closing interval (sec)	Connection fittings (Ø)	Weight (Kg)
T20	12	180	3	1.463	3	3/8" GAS	45
T30	25	180	5,9	2.872	3,5	3/8 GAS	63
T38	25	180	5,9	2.872	3,5	3/8" GAS	71
T46	30	220	9,4	4.586	4	1/2" GAS	141

Optional:  
• Extension

\* The performances are obtained with maximum pressure and flow rate  
\* Dimensions represent the equipment with the extension

• Trimeccanica company reserves the right to change, modify or improve the characteristics above at any time and without any prior notice.